

**OP-MX815L1SD-40**

**OP-MX815L1SD-40**

**Product Features**

- ✓ Duplex LC connector
- ✓ Hot-pluggable XFP footprint
- ✓ 850nm VCSEL laser
- ✓ RoHS compliant and Lead Free
- ✓ Distance up to 300m on 50/125um MMF
- ✓ Metal enclosure for lower EMI
- ✓ +3.3V power supply and power dissipation <1.5W
- ✓ XFP MSA INF-80771 Compliant
- ✓ Compliant with IEEE 802.3ae



**Applications**

- ✓ 10GBASE-SR/SW
- ✓ 10G Fibre Channel

**General**

OPTOSTAR's OP-MX885L1SD-0.3 Small Form Factor 10Gb/s XFP transceivers are compatible with XFP MSA Specification .It is designed for use in 10G-Gigabit links up to 300m of OM3. Digital diagnostics functions are available via a 2-wire serial interface, as specified in the XFP MSA.

**Product Selection**

Part Number	Operating Case temperature	DDMI
OP-MX885L1SD-0.3	Commercial(0~70°C)	Yes
OP-MX885L2SD-0.3	Industrial(-40~85°C)	Yes

**Regulatory Compliance**

- ESD to the Electrical PINs: compatible with MIL-STD-883 Method 3015
- ESD to the Duplex LC Receptacle: compatible with IEC 61000-4-2
- Immunity compatible with IEC 61000-4-3
- EMI compatible with FCC Part 15 Class B EN55022 Class B (CISPR 22B) VCCI Class B

- Laser Eye Safety compatible with FDA 21CFR 1040.10 and 1040.11 EN60950, EN (IEC) 60825-1,2
- RoHS compliant with 2002/95/EC 4.1&4.2 2005/747/EC

## ■ Pin Descriptions

Pin	Symbol	Name/Description	Ref.
1	GND	Module Ground	
2	VEE5	Optional-5.2 Power Supply-not required	
3	MOD_DESE L	Module De-select; When held low allows the module to respond to 2-wire serial interface. LVTTTL-I	
4	/INTERRUPT T	Interrupt; Indicates presence of an important condition which can be read via the 2-wire serial interface. LVTTTL-O	2
5	TX_DIS	Transmitter Disable. Logic1 indicates laser output disabled, LVTTTL-I	
6	VCC5	+5V Power Supply	
7	GND	Module Ground	1
8	VCC3	+3.3V Power Supply	
9	VCC3	+3.3V Power Supply	
10	SCL	2-Wire Serial Interface Clock. LVTTTL-I	2
11	SDA	2-Wire Serial Interface Data Line. LVTTTL-I/O	2
12	MOD_Abs	Indicates Module is not present. Grounded in the Module. LVTTTL-O	2
13	MOD_NR	Module Not Ready; Indicating Module Operational Fault. Open-collector. LVTTTL-O	2
14	RX_LOS	Loss of Signal indication. Logic 1 indicates loss of Signal. Open-collector. LVTTTL-O	2
15	GND	Module Ground	1
16	GND	Module Ground	1
17	RD-	Receiver Inverted Data Output. CML-O	
18	RD+	Receiver Non-Inverted Data Output. CML-O	
19	GND	Module Ground	1

20	VCC2	+1.8V Power Supply (Not required).	3
21	P_DOWN/R	Power down; When high, requires the module to limit power consumption to 1.5W or below. 2-Wire serial interface must be functional in the low power mode. LVTTL-I	
	ST	Reset; The falling edge initiates a complete reset of the module including the 2-wire serial interface, equivalent to a power cycle. LVTTL-I	
22	VCC2	+1.8V Power Supply (Not required)	3
23	GND	Module Ground	1
24	REFCLK+	Reference Clock (Not required)	
25	REFCLK-	Reference Clock (Not required)	
26	GND	Module Ground	1
27	GND	Module Ground	1
28	TD-	Transmitter Inverted Data Input. CML-I	
29	TD+	Transmitter Non-Inverted Data Input. CML-I	
30	GND	Module Ground	1

### Notes:

1. Module ground pins GND are isolated from the module case and chassis ground within the module.
2. Open collector, Should be pulled up with 4.7K-10Kohms to a voltage between 3.15V and 3.6V on the host board.
3. The pins are open within module.

### ■ Pin-out Connector Block on Host Board

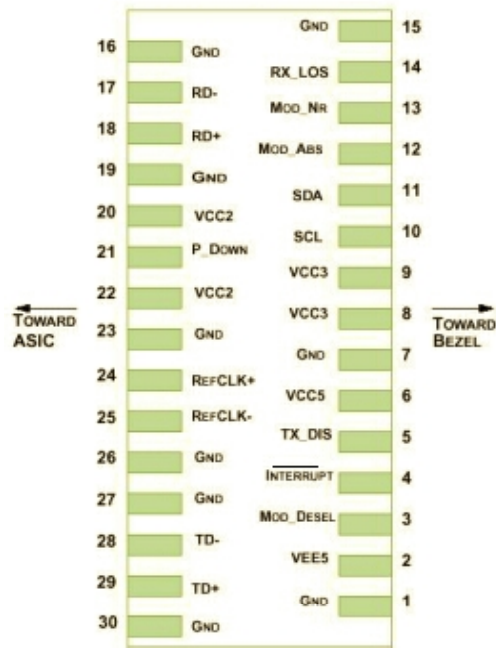

Pin-out of Connector Block on Host Board

## Recommend Circuit Schematic

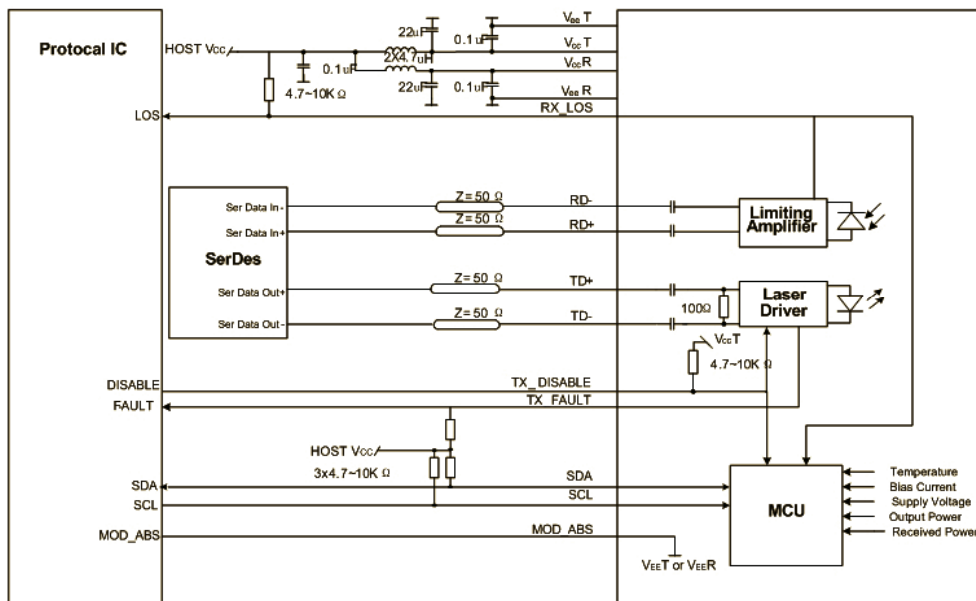

## Absolute Maximum Ratings

Parameter	Symbol	Min	Typ	Max	Unit	Ref.
Maximum Supply Voltage	Vcc3	-0.5		+4.0	V	
Storage Temperature	TS	-40		+85	°C	
Operating Humidity	RH	0		85	%	

## Recommended Operating Conditions

Parameter	Symbol	Min	Typ	Max	Unit	Ref.
Power Supply Voltage	Vcc3	3.13	3.30	3.47	V	
Power Supply Current	Icc3			430	mA	
Case Operating Temperature	Tc	0		+70	°C	Commercial
	Tl	-40		+85		Industrial
Bit Rate	Br		10.3		Gbps	
9/125um G.652 SMF	Lmax			300	m	

### ■ Electrical Characteristics (TOP=25°C, Vcc=3.3Volts)

Parameter	Symbol	Min	Typ	Max	Unit	Ref.
<b>Transmitter</b>						
Input differential impedance	Rin	80	100	120	Ω	1
Differential data input swing	Vin, pp	120		850	mV	
TX Disable-High		Vcc – 0.8		Vcc	V	
TX Disable-Low		Vee		Vee+ 0.8	V	
TX Fault-High		Vcc-0.8		Vcc	V	
TX Fault-Low		Vee		Vee+0.8	V	
<b>Receiver</b>						
Single ended data output swing	Vout, pp	300		850	mV	2
Data output rise time	Tr	30			ps	3
Data output fall time	Tf	30			ps	3
LOS-High		Vcc – 0.8		Vcc	V	
LOS-Low		Vee		Vee+0.8	V	

#### **Notes:**

1. AC coupled.
2. Into 100 ohm differential termination.
3. 20 – 80 %

### ■ Optical Characteristics (TOP=25°C, Vcc=3.3 Volts)

Parameter	Symbol	Min	Typ	Max	Unit	Ref.
-----------	--------	-----	-----	-----	------	------

Transmitter						
Output Opt. Power	PO	-5		-1	dBm	
Optical Wavelength	$\lambda$	840		860	nm	
RMS Spectral Width	$\Delta\lambda$			0.45	nm	
Optical Extinction Ratio	ER	3			dB	
Transmitter and Dispersion Penalty	TDP			3.9	dB	
Average Launch power of OFF TX	Poff			-30	dBm	
Receiver						
RX Sensitivity @10.3Gb/s	SENS			-11.1	dBm	1,2
Receiver Overload		-1			dBm	
Optical Center Wavelength	$\lambda_C$	840		860	nm	
LOS De-Assert	LOSD	-		-13	dBm	
LOS Assert	LOSA	-30			dBm	
LOS Hysteresis		0.5			dB	

### Notes:

1. Measured with conformance signals defined in FC-PI-2 Rev. 10.0 specifications.
2. Measured with PRBS  $2^{31}-1$  at  $10^{-12}$  BER.

### ■ Mechanical Specifications

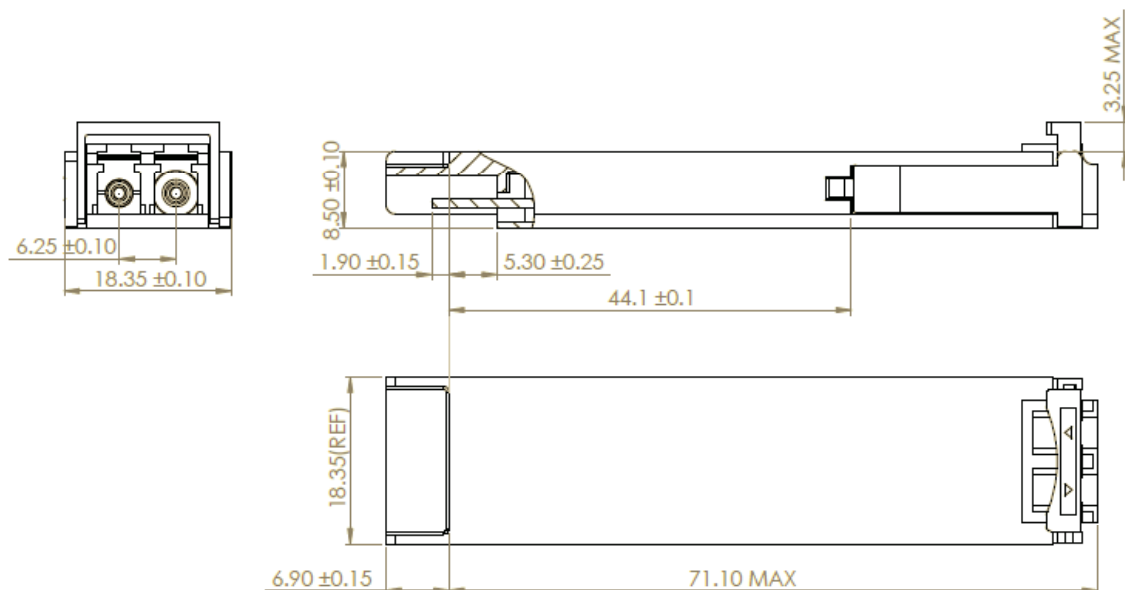

### OP-MX885L1SD-0.3

## ■ EEPROM Information

EEPROM memory map specific data field description is as below:

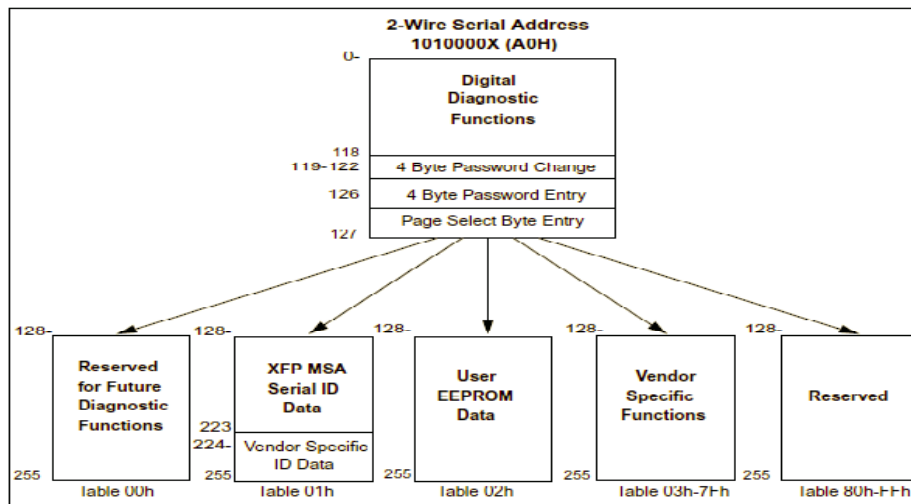

## ■ Digital Diagnostic Monitoring Interface

Five transceiver parameter values are monitored. The following table defines the monitored parameter's accuracy.

Parameter	Range	Accuracy	Calibration
Temperature	0 to +70°C (C)	±3°C	Internal
	-40 to +85°C (I)		
Voltage	2.97 to 3.63V	±3%	Internal
Bias Current	0 to 100mA	±10%	Internal
TX Power	-5 to -1dBm	±3dB	Internal
RX Power	-11.1 to -1dBm	±3dB	Internal

## ■ For More Information

Shenzhen Optostar Optoelectronics Co., Ltd

Address:A-14,Haide Building,Haide, Second Road Nanshan District,Shenzhen,P.R.China

Tel: +86-755-26400198 +86-755-26400288

Fax: +86-755-26411001

Email: info@optostar.com.cn

Skype:ouyangroya

Web: www.optostar.com.cn